

6 DEALER MANUAL FOR M210 (MM G2300.250.C)



CONTENT

6.1 Safety Instruction	2	6.3.3 Motor Installation.....	6
6.2 Production Description	3	6.3.4 Cable Connection.....	7
6.2.1 Basic Information.....	3	6.3.5 Drive Unit Cover Installation.....	8
6.2.2 Technical Specification.....	3	6.3.6 Chain Wheel Installation.....	9
6.2.3 Overall Dimension.....	4	6.3.7 Crank Installation.....	9
6.3 Installation	5	6.3.7 Speed Sonser Installation.....	10
6.3.1 List of Tools to be Used.....	5	6.4 Operation	11
6.3.2 Label Attachment.....	6	6.5 Maintenance	11

6.1 SAFETY INSTRUCTION



For safety, be sure to read this dealer manual thoroughly before use, and follow it for correct use.

Save all safety warnings and instructions for future reference.

- **Observe all national regulations which set out the approved use of e-bikes.**

- **Do not attempt to change the performance of the product. Especially increase the power of the drive unit or the maximum speed that it supports.**

Doing this may put yourself and others at risk, and you may also breach statutory regulations.

- **Do not disassemble the drive unit yourself. The drive unit must only be repaired by qualified personnel using only original spare parts.**

This will ensure that the safety of the drive unit is maintained. Unauthorised opening of the drive unit will render warranty claims null and void.

- **Be sure to follow the instructions in the manuals when installing the product.**

Only use Bafang original components and spare parts. If a component or spare part is incorrectly assembled or adjusted, it can lead to product failure or accident.

- **In order to protect the electric parts, before disassembling the product, switch off the system power first by pressing the control unit of HMI and then disconnect the power cable.**

When installing the product, fix the parts first, then connect the power cable, and finally switch on the system power by pressing the control unit of HMI.

- **After a ride, do not allow your unprotected hands or legs to come into contact with the motor housing.**

Under extreme conditions, such as continuously high torques at low travel speeds, or when riding up hills or carry loads, the housing may reach a very high temperature.

- **Be sure to also inform users of the following safety information and instructions.**

- Observe the instructions in the user manual in order to ride safely.

- Observe the appropriate rules and regulations of the country, state or region in which you use the e-bikes.

- Use the product under the supervision of someone responsible for safety, and only as instructed. - Do not allow anyone (including children) with reduced physical, sensual, or mental capacity, or those without experience or knowledge, to use the product.

- Do not allow children to play near the product.

- Never modify the performance parameters. Doing so may cause a system error or legal question.

- If any malfunction or trouble occurs, consult the place of purchase.

- For any questions regarding methods of installation and maintenance of the product, consult the place of purchase.

- Products are not guaranteed against natural wear and deterioration from normal use and aging.

6.2 PRODUCT DESCRIPTION

6.2.1 Basic Information

- **Model**

MM G2300.250.C

- **Appearance**



- **Nameplate**

The following figure shows the laser mark and QR code label on the motor housing.

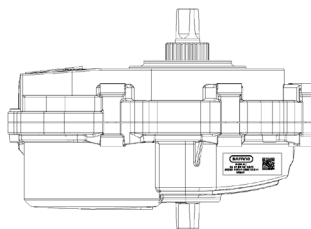

NOTICE

It is forbidden to maliciously erase, polish, stain the laser mark and QR code label, otherwise no after-sales service will be provided.

6.2.2 Technical Specification





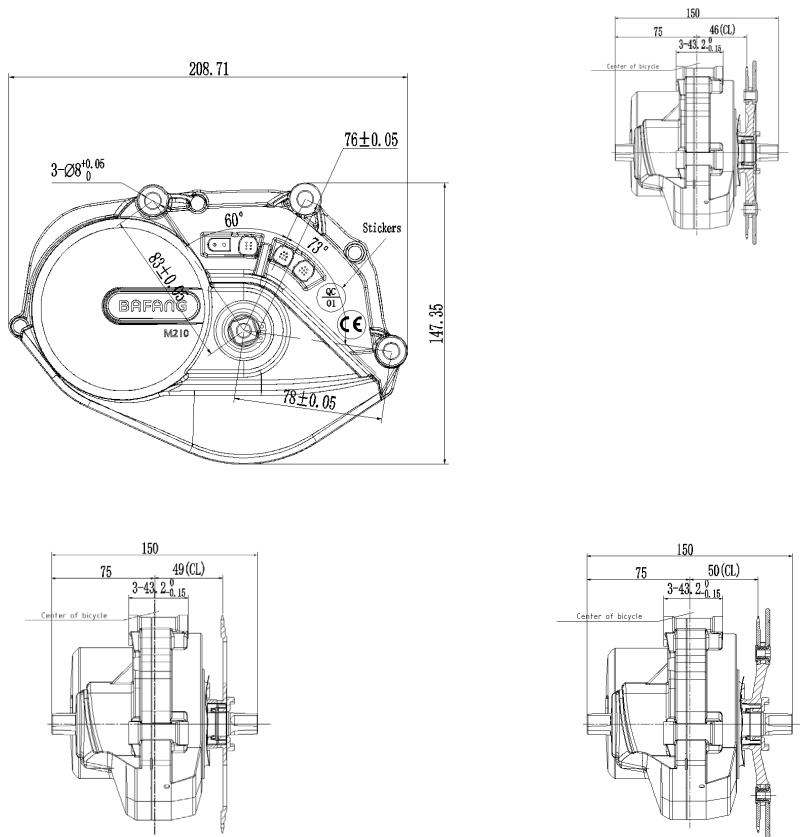

Item	Parameters	
Rated Voltage	36V	43V
Rated Power	250W	250W
Max. Torque	> 70N.m	> 70N.m
Operating Temperature	-20~40°C	-20~40°C
Storage Temperature	-25~70°C	-25~70°C
Protection Rating	IPX6	IPX6
Weight (approx.)	3.4kg	3.4kg

6.2.3 Overall Dimension



6.3 INSTALLATION

6.3.1 List of Tools to be Used

Diagram	Name	Diagram	Name
	5mm hex wrench		14mm socket
	8mm hex wrench		BB tool
	T20 screwdriver	/	Bafang tool
	PH1 screwdriver		

6.3.2 Label Attachment

Recommended place: Attach the label to the top of the drive unit.

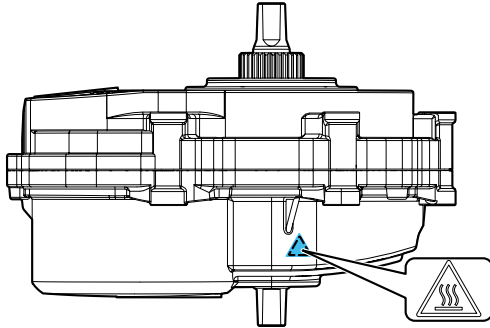

(A) Anti-scalding label

6.3.3 Motor Installation

Align the 3 mounting holes on the motor with the mounting holes on the frame.

Insert 3 M8 bolts into the 3 mounting holes on the right side of the frame and through the motor from the left side of the frame.

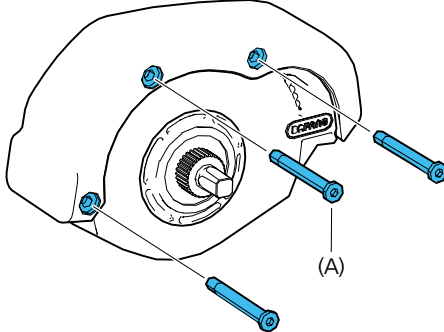

(A) M8 bolt

Tool



Tightening torque

35 N.m

Caution: Do not press the cable.

Tighten the bolts onto 3 M8 lock nuts with washers on the left side of the frame with the dedicated tool.

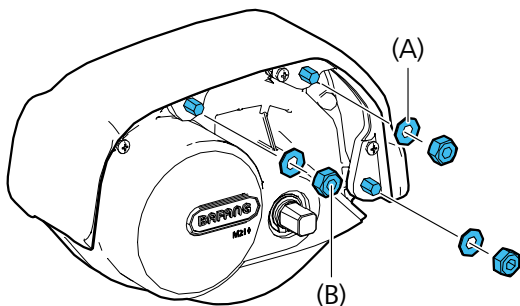

(A) M8 washer - A

(B) Lock nut

Tool



Tightening torque

35 N.m

Note: Bafang dedicated tool size: Outer diameter is 17.7 mm; the length is 63 mm.
Tool requirement: Outer diameter < 17.7 mm; the length > 63 mm.

6.3.4 Cable Connection

Connect the male connector (A) to the female connector for the battery.

Connect the male connector (B) to the female connector for the e-brake.

Connect the female connector (C) to the male connector for the rear light & sensor.

Connect the male connector (D) to the female connector for the front light & HMI.

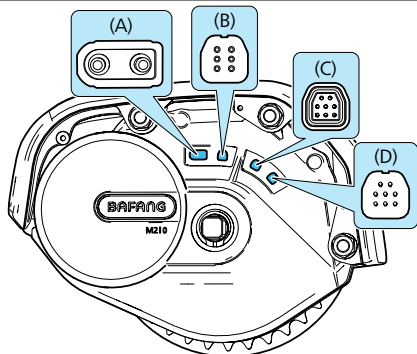

(A) Male connector for power at the drive unit

(B) Male connector (6 pin) at the drive unit

(C) Female connector (8 pin) at the drive unit

(D) Male connector (8 pin) at the drive unit

Tool

Bafang Tool

How to use the Bafang tool:

1. Hold the connector (A) with one hand, then insert the tool into the bottom of the connector (A) with your another hand.
2. Rotate the tool clockwise until they engage.
3. Use the tool to insert the connector (A) into the appropriate port (B) on the motor and lock in place.

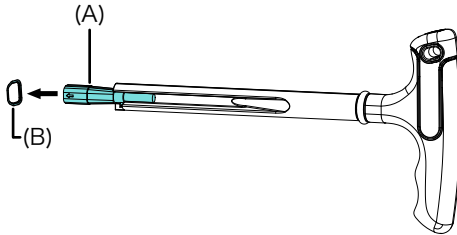

4. Rotate the tool counterclockwise to remove it.

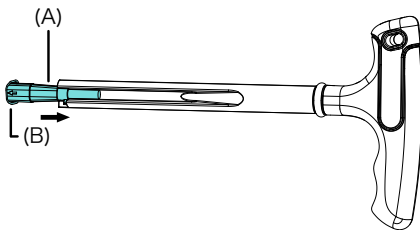

6.3.5 Drive Unit Cover Installation

Fasten the motor cover on the motor with 3 M4*8 screws.

1

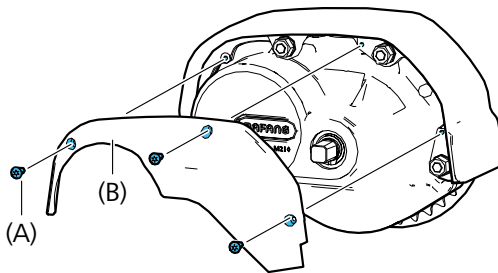

(A) M4*8 hexalobular socket screws

(B) Motor cover

Tool



Tightening torque

1.5 N.m

6.3.6 Chain Wheel Installation

Install the chain wheel into the of motor. Fasten the lock ring on motor interclockwise with the dedicated tool.

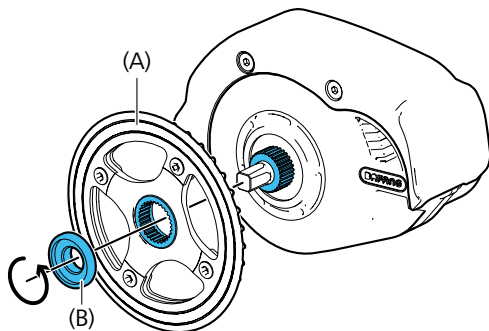

- (A) Chain wheel
- (B) Lock ring

Tool



Tightening torque

35 N.m

Caution: Do not use an impact wrench.

6.3.7 Crank Installation

To install the right crank on the shaft of the motor, fasten one M8*1 hexagon socket screw, and install the left crank as above.

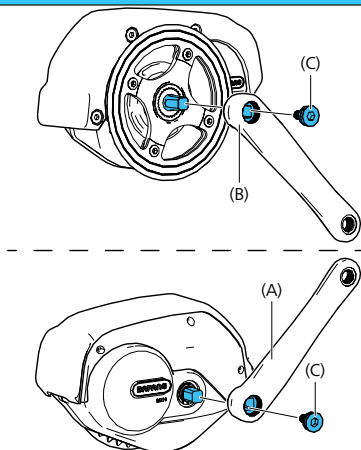

- (A) Left crank
- (B) Right crank
- (C) Crank fixing screws

Tool



Tightening torque

35-40 N.m

Note: Ensure left and right cranks are in parallel.

6.3.8 Speed Sensor Installation

Fasten the M4 screws on the speed sensor and magnet unit.

1

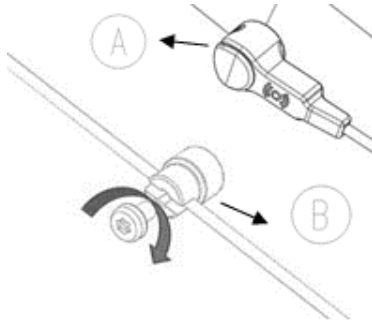

(A) Speed sensor
(B) Magnet unit

Tool



Tightening torque

A: 1 N.m

B: 1.5-2 N.m

Note:

- ▶ Ensure the clearance between the speed sensor and the magnetic unit is within 10 to 20 mm.
- ▶ The magnetic unit shall be aligned with the center of the speed sensor.

6.4 OPERATION

- Environmental conditions for operation:
 - a) Operating temperature: $-20^{\circ}\text{C}\sim 45^{\circ}\text{C}$;
 - b) Relative humidity: (20~90)%RH;
 - c) Atmospheric pressure: (86~106)kPa;
 - d) No seriously corrosive gas or no medium affecting the electrical insulation around.
- Be sufficiently familiar with how to start the drive unit before riding on busy streets, otherwise the unexpected start may result in an accident.
- Avoid water immersion during operation.
- Avoid violent impact during operation.
- Prohibit overload for a long time.
- Avoid direct touch of hands or legs with products that have been running for a long time without protection to prevent heat burns.
- Observe the appropriate rules and regulations of the country, state or region in which you use the e-bikes.

6.5 MAINTENANCE

- Maintenance must be carried out by Bafang authorized personnel with the correct equipment.
- Do not disassemble the product.
- It is recommended to regularly check whether the end cap nuts on both sides of the product are loose, whether the connector is loose, whether the shape is deformed or whether the power cord is broken.
- The components are designed to be fully waterproofed to withstand wet weather riding conditions. However, do not deliberately place them into water.
- Power off the ebike system before cleaning the product by pressing the On/Off button of HMI.
- Do not clean the product with a high-pressure washer. If water seeps into the electrical components, operating problems or corrosion may result.
- Use a damp, well wrung out cloth, when cleaning the motor housing and cover.